

ITEM NO.	PART NUMBER	DESCRIPTION	QTY.
1	Hips		1
1.1	RX_24F		3
1.2	Hip Anchor		1
1.3	90592A006	HEX NUT M2.5x0.45	25
1.4	91290A101	SOCKET HEAD CAP SCREW M2.5x0.45x6	24
1.5	Hip L		4
1.5.1		Sheet	-
2	RX_24_to_MX_64_2		2
2.1	RX_24_to_MX_64		1
2.1.1	RX_24F		1
2.1.2	RX_24_E		1
2.1.3	MX_64_H		1
2.1.3.1		Sheet	-
2.1.4	90592A006	HEX NUT M2.5x0.45	4
2.1.5	91290A101	SOCKET HEAD CAP SCREW M2.5x0.45x6	12
2.2	MX_64R		1
2.3	91290A099		10
2.4	MX_64_E		1
2.4.1		Sheet	-
2.5	91290A101	SOCKET HEAD CAP SCREW M2.5x0.45x6	4
2.6	90592A006	HEX NUT M2.5x0.45	4
2.7	RX_24_H		1
2.7.1		Sheet	-
2.8	91290A011	SOCKET HEAD CAP SCREW M2x0.4x4	18
3	Shoulder		1
3.1	RX_24F		2
3.2	Shoulder Anchor		1
3.3	Shoulder Anchor Front		1
3.4	91290A011	SOCKET HEAD CAP SCREW M2x0.4x4	10
3.5	91290A101	SOCKET HEAD CAP SCREW M2.5x0.45x6	20
3.6	90592A006	HEX NUT M2.5x0.45	20
4	Front_leg		2
4.1	RX_24F		2
4.2	RX_24_E_to_RX_24		2
4.3	RX_24_H		2
4.3.1		Sheet	-
4.4	91290A011	SOCKET HEAD CAP SCREW M2x0.4x4	36
4.5	91290A101	SOCKET HEAD CAP SCREW M2.5x0.45x6	8
4.6	90592A006	HEX NUT M2.5x0.45	8

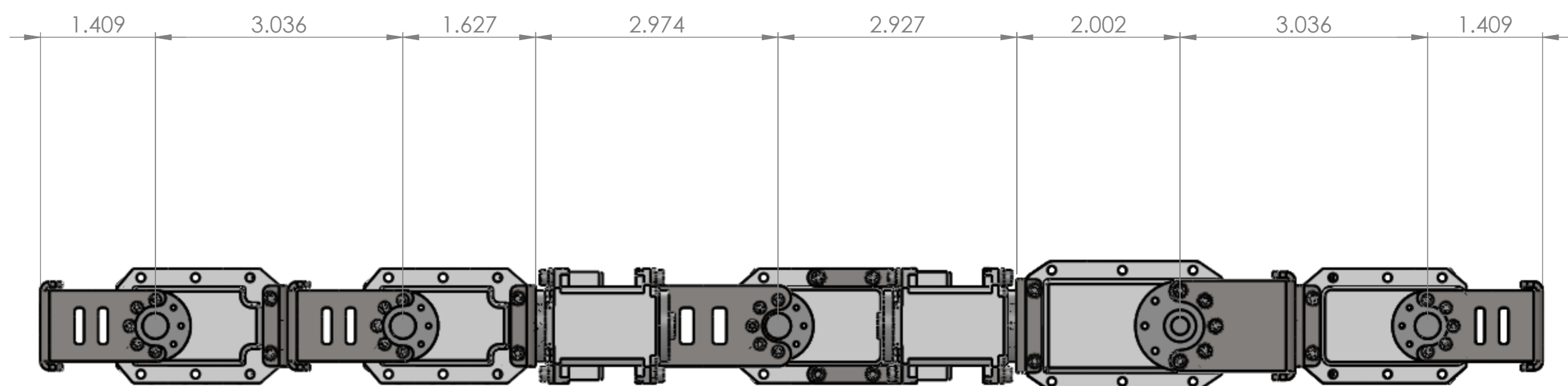
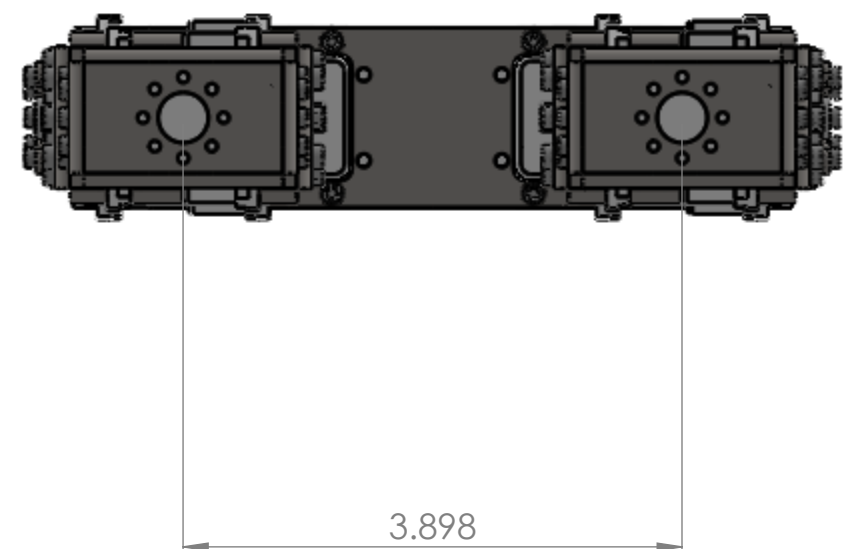
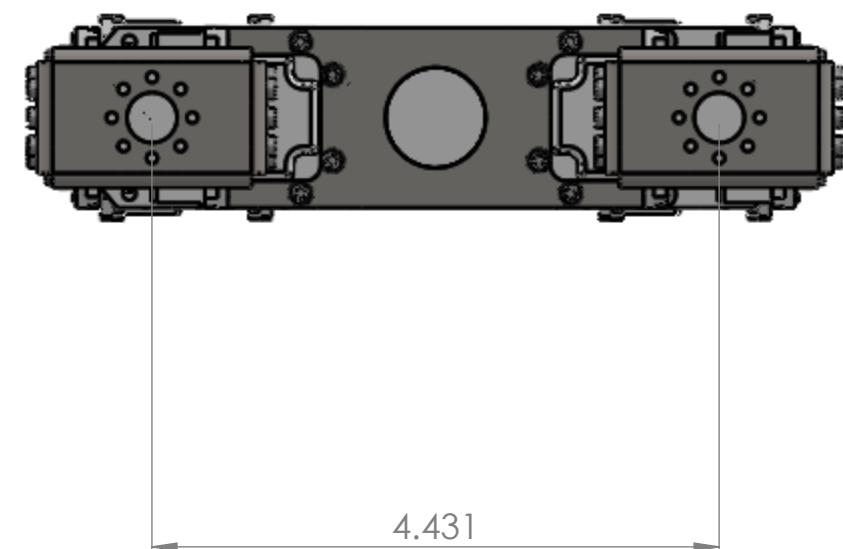
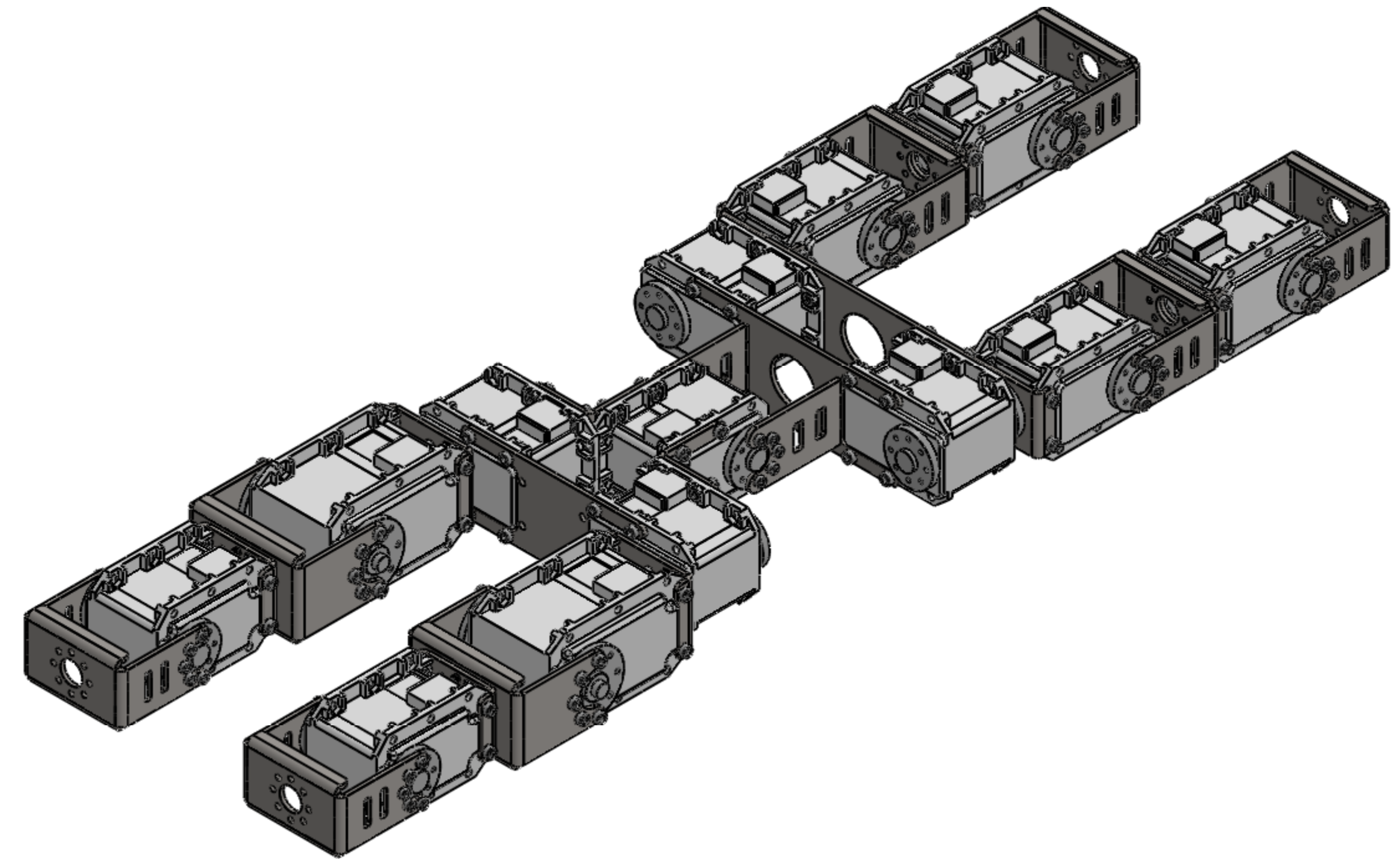
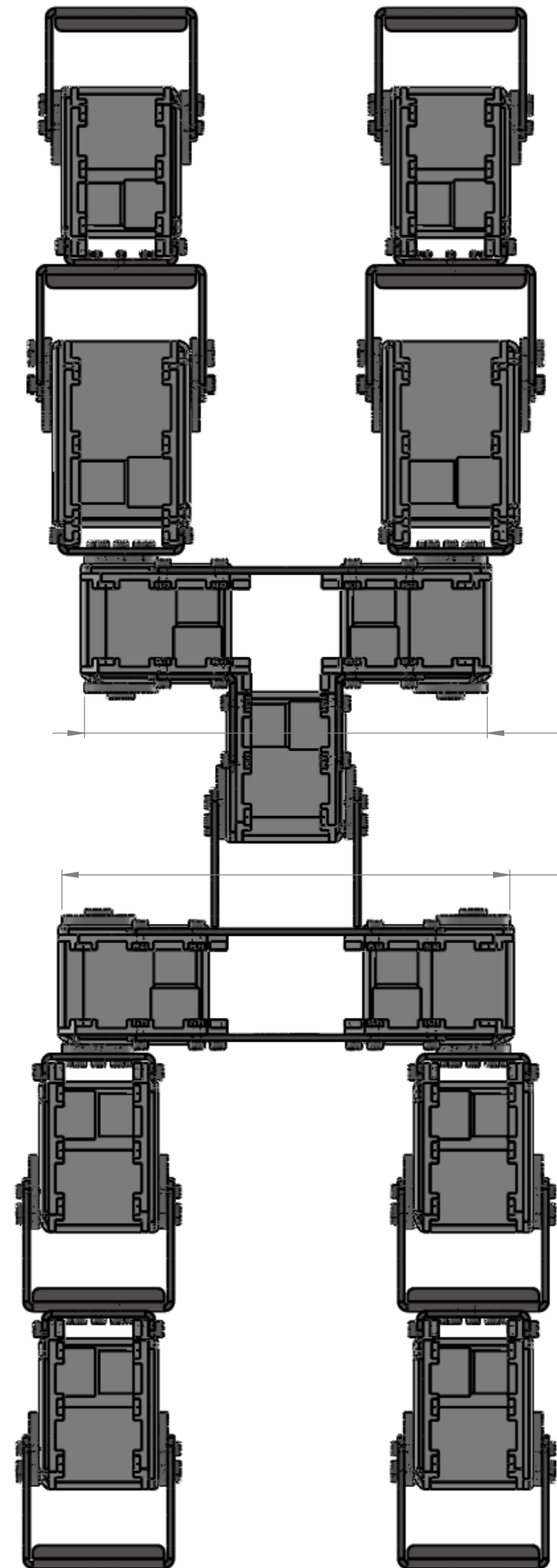

PROPRIETARY AND CONFIDENTIAL
 THE INFORMATION CONTAINED IN THIS DRAWING IS THE SOLE PROPERTY OF JON TORREY. ANY REPRODUCTION IN PART OR AS A WHOLE WITHOUT THE WRITTEN PERMISSION OF JON TORREY IS PROHIBITED.

UNLESS OTHERWISE SPECIFIED:		NAME	DATE
DRAWN	J.TORREY		8/18/14
CHECKED			
ENG APPR.			
MFG APPR.			
INTERPRET GEOMETRIC TOLERANCING PER MATERIAL		Q.A.	
NEXT ASSY USED ON FINISH SPRAY PAINT		COMMENTS:	
APPLICATION			

TITLE:		SIZE	DWG. NO.	REV
		D	Lynx	B
SCALE: 1:1.5WEIGHT:		SHEET 1 OF 1		